

A New Generation of Compact Precision Reducers  
Created by the Triple Crown Gear

Long Lifespan × High Torque

# CROWN ROBOXGEAR



**CROWN  
ROBOXGEAR**

# Robust and Powerful Precision Compact Reducer

The Crown Roboxgear, a nutation reducer, adopts the Crown Reduction Mechanism, a simple gear configuration consisting of three rigid gears: the rotor gear, stator gear, and output gear.

Compared to planetary gear mechanisms, oscillating reducers, and harmonic reducers, it is a new type of reducer for the robotic era that strikes a balance between compactness, robustness, and longevity.



Rotor gear



Output gear

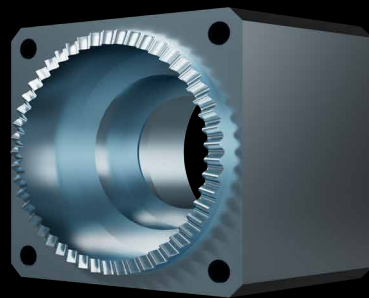

Stator gear

## Operating Mechanism

**1** The outer side of the rotor gear contacts the stator gear whereas the inner side of the rotor gear contacts the output gear.

**2** The motor's rotational movement is transmitted through the press rotor and converted into the rotor gear's precessional motion.

**3** The precessional movement of the rotor gear, engaging with the stator gear with a different tooth count, causes deceleration, which is then transferred to the output gear to perform the reduction operation.



Watch the video on the operating mechanism here!

The “robustness” required for precision compact reducers in the era of small robots means powerful torque, high rigidity for shock resistance, and longevity to operate continuously in high-load environments.

## Robustness

### High Torque

Increased rated torque for the reducer to maximize small motor power (double the torque for the same size)

### Shock Resistance

Instantaneous Maximum Torque: **45**Nm (for the 30-mm external dimension type)

## Longevity

### High Load Resistance

Rated Torque: **3**Nm (for the 30-mm external dimension type)

# The Optimal Reducer for Miniaturization and Lightweighting

To achieve a large reduction ratio in small precision reducers that require precise control, it is common to use a differential gear reducer mechanism with a large reduction ratio per tooth. Among these, the Crown Reduction Mechanism, classified as a nutation reducer, is structurally suitable for miniaturization, offering high torque while maintaining positional accuracy during actual operation. The Crown Roboxgear has been further refined to create an ultra-compact yet powerful reducer ideal for various use cases, such as small robots.

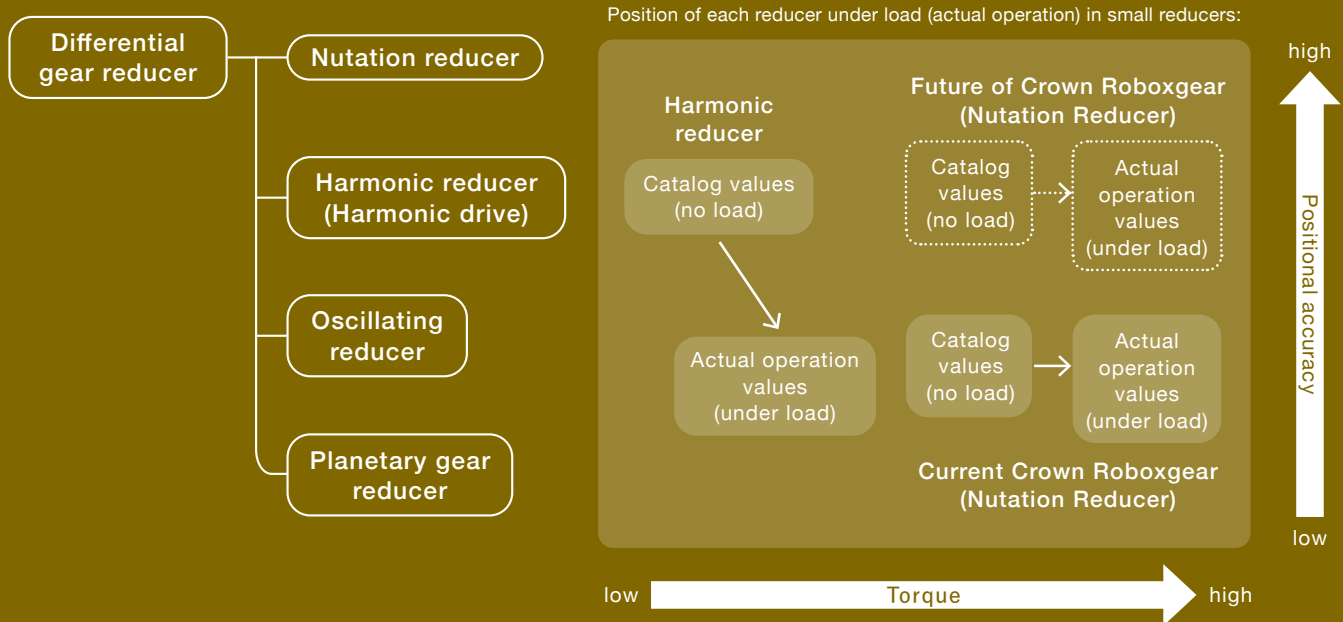
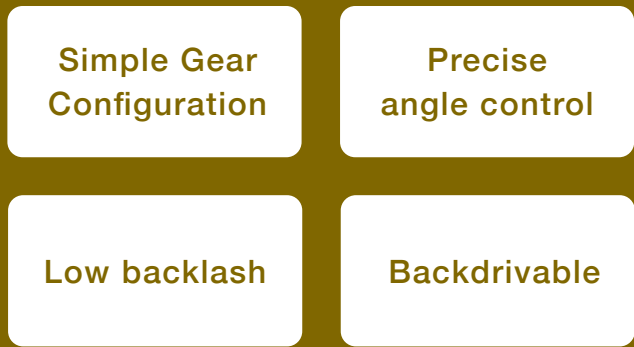

## High-Load Torque Lifespan Test Data

The high-load torque lifespan test is a straightforward way to demonstrate strength and longevity. The rated torque is the value used when the total rotation count reaches  $10^9$ , and currently, it has achieved approximately double the strength of typical harmonic reducers. The testing is ongoing, with the final goal being to achieve double the current rated torque.

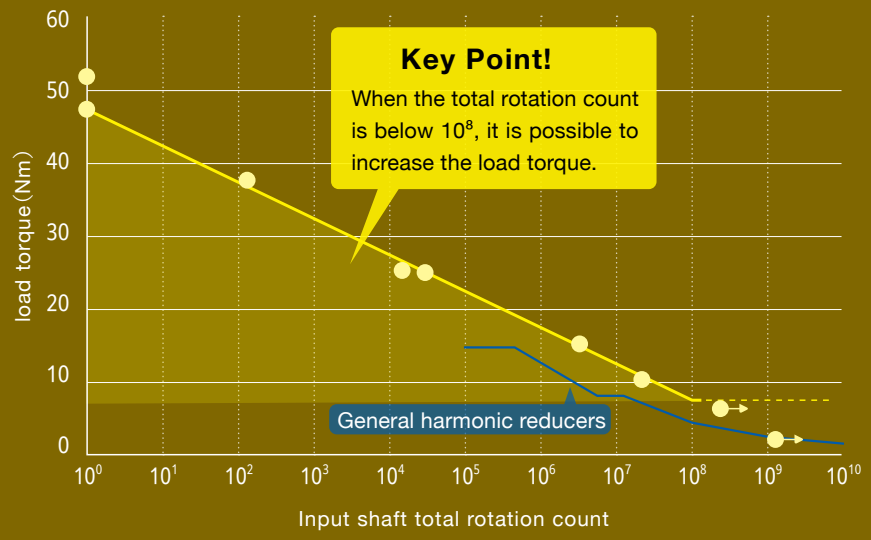

# Lineup

## Crown Roboxgear

### Solid Type



The basic unit, offering greater rigidity than the hollow type, is more cost-effective and can be connected to various motors.

### Hollow Type



The rotating shaft is tubular, allowing wiring to pass through the shaft or the hollow hole to be used for connecting other devices, achieving space-saving design.

### Geared Motor Type



By integrating the motor and the reducer, space-saving and torque optimization are achieved for the entire unit.

## CRGN13 | Geared Motor Type

External Dimensions

**13 mm**

Reducer Unit Mass:25g    Rated Torque:0.3Nm    Instantaneous Maximum Torque:0.8Nm

Intended Applications: Finger joints of robot hands, and robot joints for small precision fields.



As the flagship model representing Crown Roboxgear, which is optimal as an ultra-compact, high-output precision reducer, it achieves twice the rated torque and more than 2.6 times the instantaneous maximum torque of typical ultra-compact reducers of the same size. It adopts Oki Micro Engineering's high-torque, ultra-compact brushless DC motor Thumbelina for the motor.

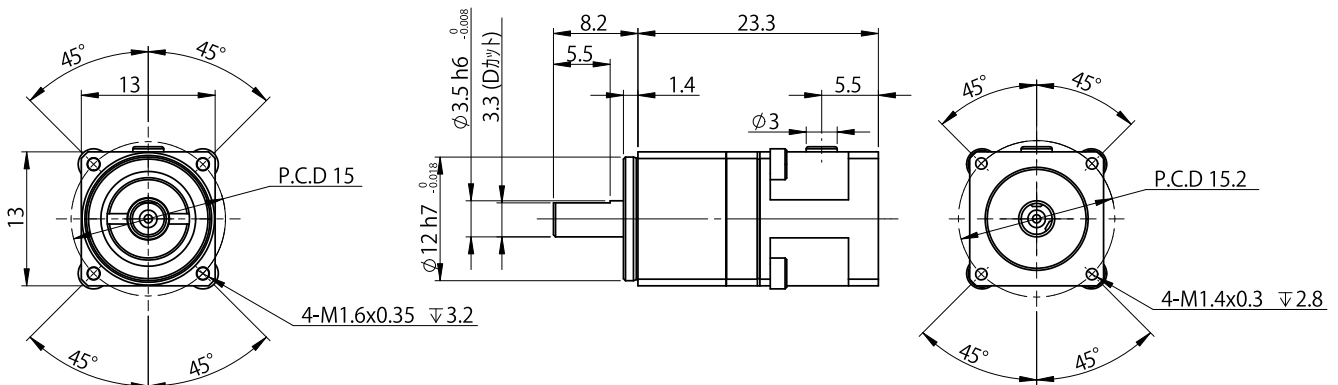

# CRGS30 | Solid Type / Geared Motor Type

External Dimensions  
**30 mm**

Optimized for 30-W servo motors, and if the external dimensions of Oriental Motor's AZ series (our collaborating manufacturer) are used, it can utilize the motor's maximum excitation holding torque.

## CRGS30-050FDD | Solid Type

Reducer Unit Mass:200g | Rated Torque:3Nm | Instantaneous Maximum Torque:45Nm

Intended Applications: Robot joints, miniaturization of existing reducer units, etc.

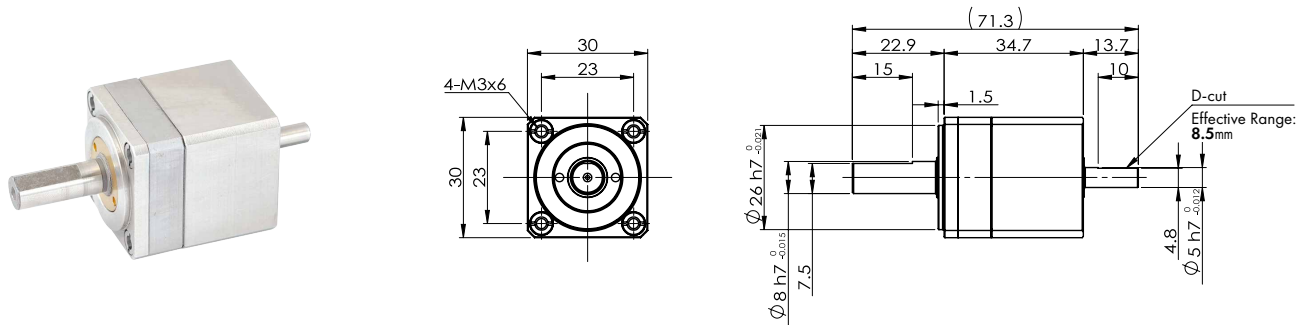

## CRGS30-050FDM1 | Geared Motor Type

Reducer Unit Mass:165g | Rated Torque:3Nm | Instantaneous Maximum Torque:45Nm

Intended Applications: FA equipment, robot joints.

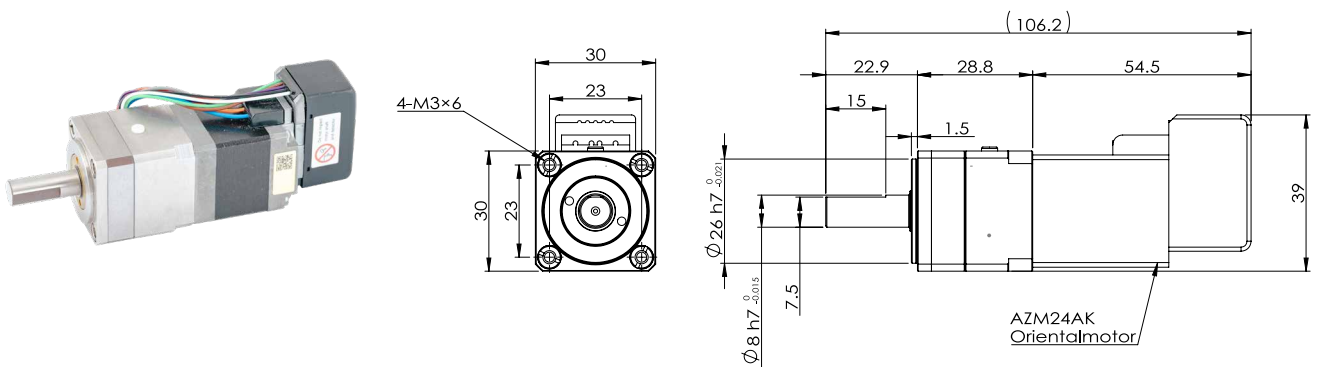

# CRGH50 | Hollow Type

External Dimensions  
**50 mm**

Reducer Unit Mass:320g | Rated Torque:3Nm | Instantaneous Maximum Torque:45Nm

Intended Applications: Robot arm joints, CNC machines, conveyor systems, medical devices, etc.

Among precision compact reducers, those with external dimensions over 50 mm are somewhat larger and are required for applications such as robot arms that need to lift heavy objects with high torque and high load resistance. A hollow type is provided to achieve compactness in any combination of units.

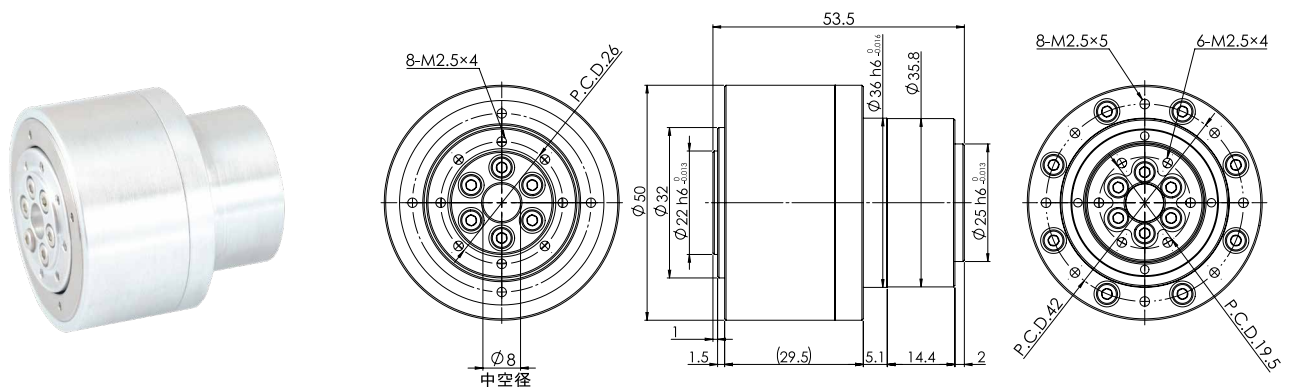

## Specifications

Reducer diameter (External dimensions)	Model	Weight-Rated	torque	Starting torque	Maximum backlash	Angular transmission error	Instantaneous maximum torque	Maximum allowable input rotation speed	Efficiency	Reduction ratio
8mm	Solid type	25g	0.3Nm	3mNm	0.4°	0.4°	0.8Nm	10000rpm	50%	30 50 100
	Geared motor type									
										
13mm	Solid type	25g	0.3Nm	3mNm	0.4°	0.4°	0.8Nm	10000rpm	50%	30 50 100
	Geared motor type									
20mm	In development									
30mm	Solid type	200g	3Nm	13mNm	0.25°	0.25°	45Nm	3500rpm	52%	30 50 100
	Hollow type									
	Geared motor type	165g								
40mm	in planning									
50mm	Hollow type	320g	3Nm	20mNm	0.25°	0.25°	45Nm	3500rpm	52%	30 50 100

[Glossary of Terms]

----- In development    - - - - - in planning

Starting Torque: The minimum torque required on the input shaft to initiate rotation on the output side.

Maximum Backlash: The gap or play between the gear teeth surfaces that occurs when the rotor gear and stator gear or the rotor gear and output gear mesh.

Angular Transmission Error: The difference between the theoretical rotational angle of the output shaft and the actual rotational angle when the input shaft is rotated by a certain angle.

Instantaneous Maximum Torque: The maximum torque that can be applied to the output shaft.

Efficiency: The ratio of mechanical work extracted from the output shaft to the mechanical work applied to the input shaft (this is a reference value, for it varies depending on usage conditions).

## Use Cases

### Rotating Lid Mechanism for Panoramic Window (LIXIL Corporation)

Our Crown Roboxgear has been adopted as the gear reduction mechanism supporting the rotating lid functionality in LIXIL's panoramic window SEAMLESS. Its strength and reliability—allowing it to withstand loads of up to 200 kg without reverse rotation despite its compact size—were key factors in its selection.



### μDynamics Gripper (Orimvexta Co., Ltd.)

Orimvexta Co., Ltd. is selling an electric gripper equipped with our proprietary Three-dimensional Cam Mechanism and Crown Reducer. Despite its compact and lightweight design, it can perform precise operations such as gripping with a force of up to 20 N and grasping a 0.5 mm mechanical pencil lead.



## Contact Information

### Mu Lab, LTD.

1 Kanayagawa, Fukushima City,  
Fukushima Prefecture, 960-1296, Japan  
Fukushima University  
Venture Incubation Room  
Phone: +81-24-563-7181

Established in April 2015 as the first startup company from Fukushima University, Mu Lab designs develops, and manufactures precision equipment for robots. The company has successfully commercialized Fukushima University's proprietary technologies, including the Crown Reducer and 3D Cam Mechanism.

Youtube



Official website



**μ Lab.**  
amazing innovations for the future.